

FF-E Series

Freon Flake Ice Making Systems



FF-E Series (Freon Flake Evaporator, no refrigeration included)

Available in 1 Ton, 1.5 Ton, 2 Ton, 2.5 Ton, 3.2 Ton, 5 Ton, 10 Ton, 15 Ton, 20 Ton, 30 Ton, 40 Ton and 50 Ton.

The FF-E Series is suited to those Contractors that may wish to combine a single, or multiple evaporators together, operating on a common refrigeration plant.

The E series comes complete with control system, water pump, and gear motor assembly. This offers a choice for the Customer to use their preferred refrigeration equipment.

Warranty: 3 years parts and labour.

Model list:

FF1E/FF1.5E/FF2E/FF2.5E/FF3.2E/FF5E

COAST Ice & Cold Solutions

Dimensions Without Packing

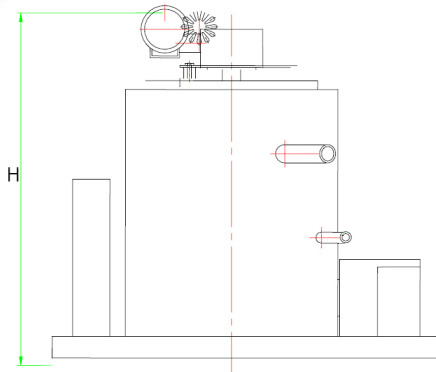

Model	W	D	H
FF1E	850mm	1050mm	870mm
FF1.5E	850mm	1050mm	1050mm
FF2E	850mm	1050mm	1080mm
FF2.5E	850mm	1050mm	1250mm
FF3.2E	850mm	1050mm	1300mm

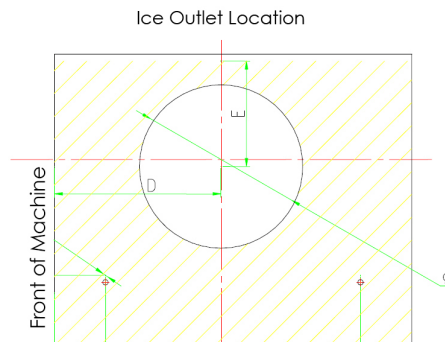
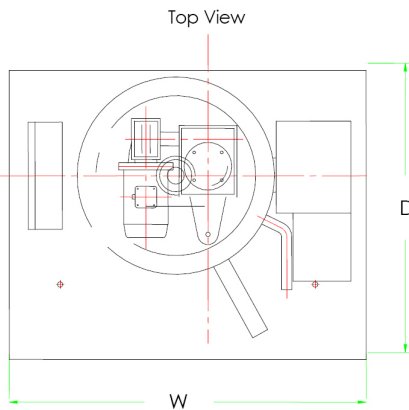

Ice Outlet Dimensions Table

Model	D	E	Ice Outlet Inter. Dia. Φ
FF1E	490	310	480
FF1.5E	490	310	480
FF2E	490	310	480
FF2.5E	490	310	480
FF3.2E	490	310	480

Parameters of Technology

Model	Ice Capacity per 24hr	Refrigeration Capacity	Gear Box Motor	Water Pump Power	Voltage	Water Consumption	Inlet Water Connection	Drainpipe External Diameter	Net Weight
FF1E	1000kg	5.5KW	180W	10W	380V/50/3	42L/H	3/4" GAS	Ø21mm	170kg
FF1.5E	1500kg	8.5KW	180W	10W	380V/50/3	63L/H	3/4" GAS	Ø21mm	200kg
FF2E	2000kg	11KW	180W	20W	380V/50/3	85L/H	3/4" GAS	Ø21mm	230kg
FF2.5E	2500kg	13.75KW	180W	20W	380V/50/3	104L/H	3/4" GAS	Ø21mm	260kg
FF3.2E	3200kg	17.6KW	180W	20W	380V/50/3	133L/H	3/4" GAS	Ø21mm	280kg

Standard conditions: Ambient 25°C – Water Temperature 15°C

Refrigerant: 404A

Condensing Temp: 40C

Suction Temp: -22C

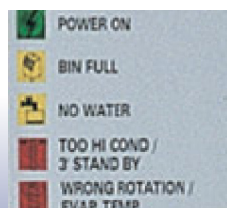

SYDNEY OFFICE
46 Box Road
Taren Point NSW 2229
Phone: (02) 9524 1234
Fax: (02) 9524 0968

Coast Distributors Pty Ltd
ABN 86 002 020 162
www.coastdistributors.com.au
July 2016

MELBOURNE OFFICE
25/44 Mahoneys Road
Thomastown VIC 3074
Phone: (03) 9460 1095
Fax: (03) 9460 1357